

SUPPLEMENT TO THE  
OWNER'S INSTRUCTION MANUAL

16mm Sound Projector

***AUTO-REPEAT  
PROJECTOR***

# EIKI MODEL SL-AR0 (AR-1, -2) AUTO-REPEAT PROJECTOR INSTRUCTIONS

## INTRODUCTION:

The Eiki Auto-Repeat Projector is basically an SL-0 (or SL-1, -2) Projector with additional automatic, repeat and stop features. It is recommended that the user be thoroughly familiar with the operation of the SL-0 (-1, -2) Projector. Before proceeding, see SL-0 (-1, -2) Instruction Manual.

## 1. PROGRAMMING A FILM FOR AUTO-REPEAT :

1-1. With the "Auto-Repeat Switch" in the "Off" position and the function switch rotated to the "Stop" position, load the film in the projector and advance the film to the desired starting frames. (See Fig. #1).

**NOTE:** For reliable performance, use the good film of suitable length. See CAUTION of page 5.

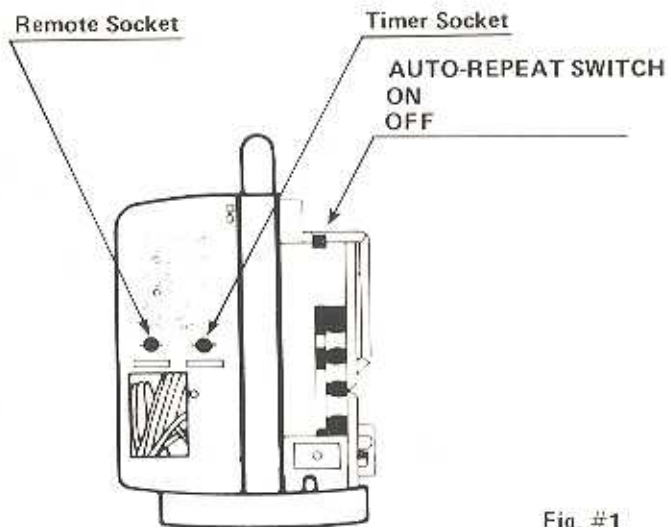

Fig. #1

- 1-2. Count back approximately 107 frames or about 81cm (32'') and attach 2 foil dots (side toward the lamp) exactly one frame apart. (See Fig. #2). Care should be taken not to cover a sprocket hole or the sound-track. (See Fig. #3).

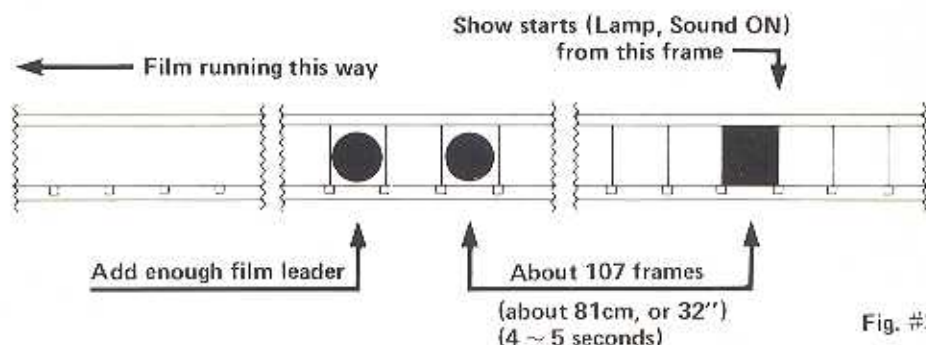
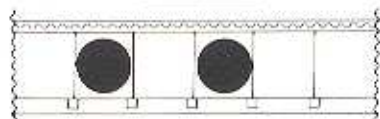

Fig. #2

CORRECT



Space one frame apart.

INCORRECT

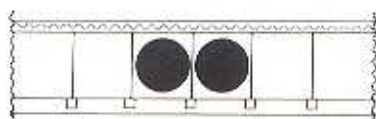

Spacing too close

INCORRECT

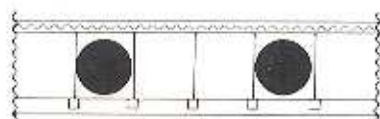

Spacing too far

INCORRECT

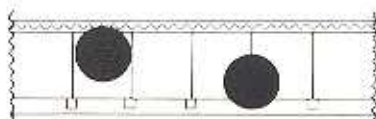

Do not cover the sound track,  
or perforations.

Fig. #3

- 1-3. Measure the film from the foil dots to the end of the film leader. Depending upon the type and size of reels used, it may be necessary to add additional leader. (See Fig. #2 and the chart below)  
 (Insufficient leader will not allow the projector to coast to a stop after rewind without losing the film's attachment to the take-up reel).

Length of film	Type of Reel		Proper Length of film leader
	Supply Reel	Take-Up Reel	
2000Ft	Plastic	Plastic, or Aluminium	12m (40')
		Metal	9m (30')
2000Ft	Aluminium	Plastic, or Aluminium	11m (36')
		Metal	15m (50')
2000Ft	Metal	Plastic	8m (26')
		Aluminium	12m (40')
		Metal	16m (53')
1200Ft	Plastic, or Metal	Plastic, or Metal	7m (23')
400Ft	Plastic, or Metal	Plastic, or Metal	2m (6-1/2')

- 1-4. With the film loaded, function knob in the "Stop" position, manually advance the film with the two leading foil dots just beyond the last roller. (See Fig. #4).

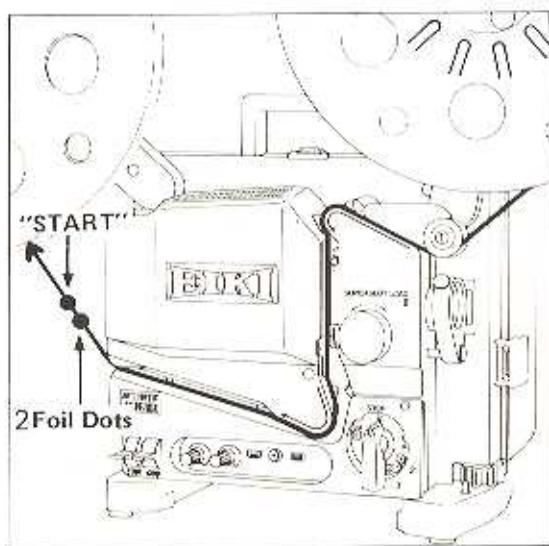

Fig. #4

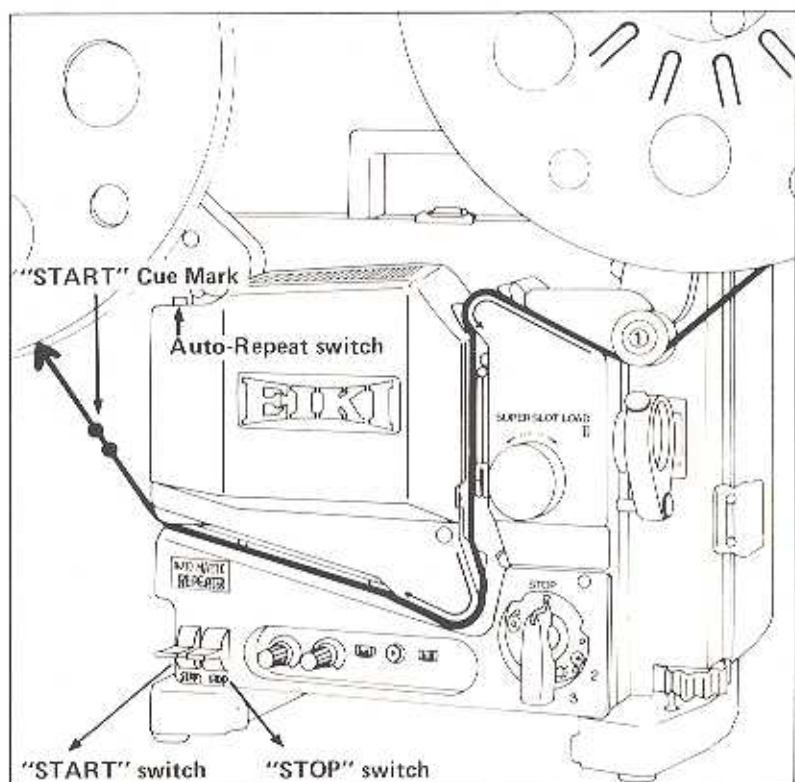

Fig. #5

- 1-5. Switch "On" the "Auto-Repeat Switch". Depress the "Start" switch. (See Fig. #5). The projector will now automatically advance the function control to forward and after approximately 4-5 seconds (107 frames (81cm), (32")), will turn on the lamp and sound.
- 1-6. When the end of the film is reached, or the desired place to stop, or the desired place to start rewinding is reached, depress the "Stop" switch. (See Fig. #5.)
- 1-7. Manually rotate the function control knob to "Stop".

- 1-8. Locate the desired frame where the film is to stop, count back about 40 frames (12'), and place two foil dots exactly one frame apart. There should be at least 2m (7') of trailer left on the supply reel.

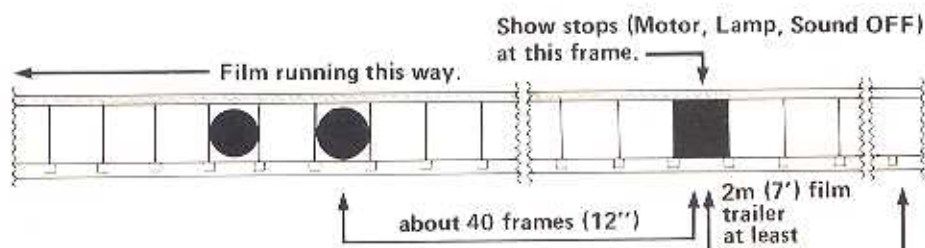

Fig. #6

- 1-9. Manually rotate the function control to "Rewind". The projector will now rewind back to the beginning foil dots and stop. The reels will slowly coast to a stop, and after a 8 second pause, the projector will advance forward to the beginning two foil dots and stop. This is the end of programming, and the film is now ready for the repeat show, either by automatic or manual command.

**CAUTION:** When a short program film is used, for reliable performance, it is always suggested to allow at least 26m (85') film length between "START" and "STOP/REWIND" que marks. (Fig. #7)

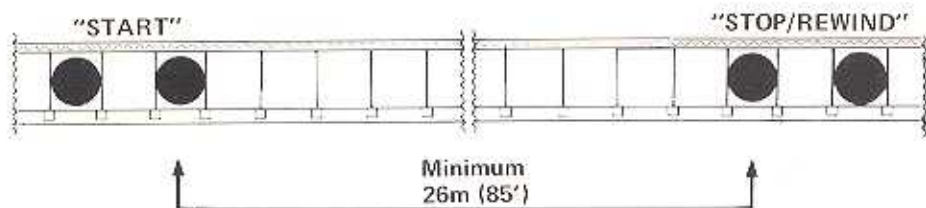

Fig. #7

## 2. AUTOMATIC OR MANUAL REPEAT OPERATION:

With the Start Cue Mark (or 2 foil dots) just beyond the last roller (See Fig. #5), the projector is ready for the repeat show either Automatic, or Manually.

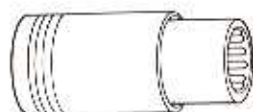

Fig. #8

Auto-Repeat  
Dummy Plug

### 2-1. Automatic Repeat:

- a. Turn on the "Auto-Repeat" switch.
- b. Plug in the "Auto-Repeat Dummy Plug" to the timer socket. (See Fig. #8 & #1)  
**(Caution:** When plugging or unplugging the "Auto-Repeat Dummy Plug", always depress the "STOP" switch, (See Fig. #5) to prevent the erroneous activation of the optical sensor.
- c. To start, depress the "START" switch. The film runs, and 4-5 seconds later, the lamp and the sound are turned on.
- d. When the "STOP" Cue Mark is sensed by the optical sensor, the film stops.
- e. The projector automatically starts rewinding the film.
- f. When the "START" Cue Mark is sensed by the optical sensor, rewinding is stopped. The film will keep running for a few feet due to inertia.
- g. The film stops completely. After a 8 seconds pause, the film advances automatically to the beginning 2 foil dots to repeat the show.
- h. The optical sensor senses the "START" Cue Mark, 4-5 seconds later, the lamp and the sound comes on, the show is re-started automatically.
- i. During the Automatic Repeat Function, if required, the show can be interrupted by depressing the "STOP" switch. To restart, depress "START" switch.

## 2-2. Manual Repeat:

When required, a manual repeat of the show is possible.

- Make sure that the "Auto-repeat Dummy Plug" is unplugged.
- Turn on the "Auto-Repeat" switch. Follow the same sequences c – g as described in 2-1.
- When the "START" Cue Mark is sensed by the optical sensor, the film stops.
- To re-start the show, depress the "START" switch, and the projector operates as sequences c – g described in 2-1.

## 3. OPTIONAL MULTIPLE STOPS:

3-1. The film may be programmed to automatically stop at any point by placing a single foil dot on the film about 40 (12") frames ahead of the desired frame. (See Fig. #9).

3-2. The program may be resumed by depressing the "START" switch.

3-3. The lamp and sound comes on approximately 107 frames from the stopping point or 4-5 seconds later. (See Fig. #9).

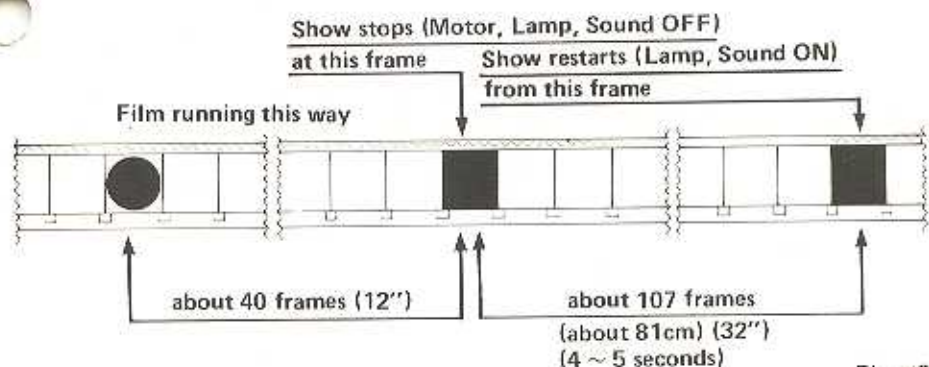

Fig. #9

3-4. Any number of intermediate stops can be programmed, however for reliable performance at least 30 seconds of time should be allowed from the beginning of the sound and picture from one stop to that of the next stop.

## 4. TIMER CONNECTOR

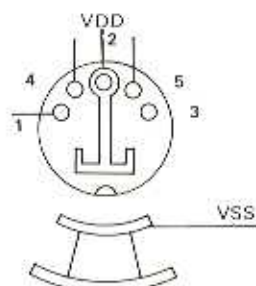

Fig. #10

The projector is provided with operational status output to the timer connector. This information may be used for interfacing with other program functions or automatic programmable timers to restart the show.

A 12 volt positive logic pulse is required to start the projector. Status signals consisting of 12 volt positive logic pulse appear at the timer connector at the various stop or pause modes. These output pulses may be used for custom designed interfaces to perform a variety of functions. Some examples may be operating curtains, lights, background music systems, raising and lowering screens, or even relaying signals from one projector to start additional projectors.

Connecting pins 1 & 5 (Fig. #8) together restarts the projector after rewind for a continuous repeating operation.

Pin #	Function	Signal
#1	Start Pulse	.1 Sec Min 12V
#2	Supply Voltage (VDD)	12 VDC max 100mA
#3	Not Used	
#4	a. Intermediate Stop (one foil dot)	.5 Sec 12V
	b. End of Film Rewind (two foil dots)	.5 Sec 12V
	c. Ready Cue or Standby	.5 Sec 12V
#5	Ready Cue or Standby (only)	.5 Sec 12V
Case	Negative Supply (VSS)	

NOTE: Auto-Repeat Dummy plug should be used to turn off the switch.

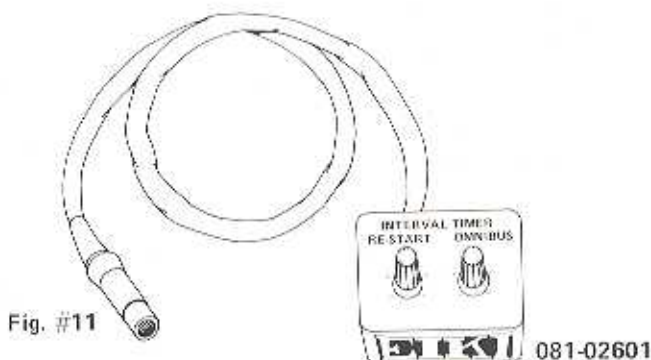

## 5. REMOTE CONTROL

The projector may also be remotely controlled from any custom installed push button.

Momentary contact between pins 3 & 2 starts the show and contact between pins 1 & 2 stops the projector at any point similar to that of a single foil dot. (Fig. #12)

Remote wiring can be up to 5m (15 feet). Longer distances up to 20m (60 feet) is possible with properly shielded cable. (Fig. #13)

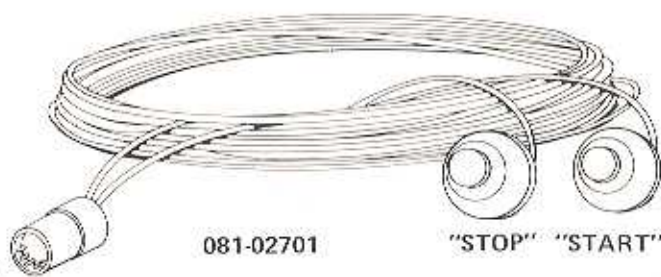
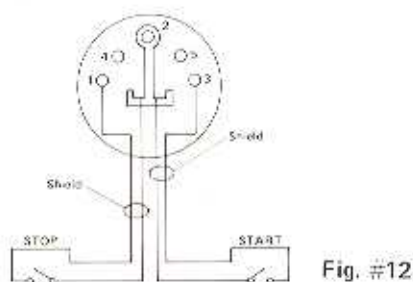

Fig. #13

## **ADDITIONAL FEATURES AND PRECAUTIONS :**

1. Safety "Film Guard" Switch is provided, the same as a conventional SL Projector model, where damaged film causing a loss of the upper loop will activate the "Film Guard" switch. In this case the projector will stop, the rotary function switch will return to the "Stop" position, reforming the upper and lower loops, the rotary function switch will then return to forward and resume the show.
2. Manual or Emergency "Stop" Switch is provided to stop the projector at any point in the show or during the rewind period. In forward to resume the operation depress the "Start" switch. In rewind, return the function switch to "Stop", then depress "Start" to resume the forward operation, or switch "Off" the Auto-Repeat switch to resume rewind.
3. Manual Operation of the Rotary Function Switch may be accomplished when the Auto-Repeat Switch is "Off".

Distributed by:

Manufactured by:

**EIKI INDUSTRIAL CO., LTD.**

C.P.O. Box 1229, Osaka, 530-91, Japan

Phone: (06) 311-9479

**EIKI INTERNATIONAL, INC.**

27882 Camino Capistrano, Laguna Niguel,  
CA, 92677 U.S.A. Phone: (714) 831-2511